



ONE CARRY-ON BAG ALLOWED FOR PASSENGERS TRAVELLING TO THE UNITED STATES

Transport Canada now permits one small carry-on bag for airline passengers who are travelling to the United States. This carry-on bag must not exceed a size of 23 cm x 40 cm x 55 cm (9 in x 16 in x 22 in), which is equivalent to the size of a small gym bag. The carry-on bag must fit into an airport’s carry-on baggage sizer.

Items such as reading material, personal electronics, and medications must be stored in the passenger’s carry-on bag, and packed prior to the security check.

As always, the Government of Canada is ensuring that exceptions are made to accommodate travellers with medical conditions or travelling with small children:

- A cane, walker, crutches or other life-sustaining items may be carried in addition to the carry-on bag.
- Medical equipment (oxygen tank, doctor’s bag) may be carried in addition to the carry-on bag.
- Diaper bags and other essential items for those carrying infants may be carried in addition to the carry-on bag.

Exemptions Include:

- One of the following will be permitted in addition to the carry-on bag: a purse or laptop or briefcase or camera bag.
- A musical instrument may be carried in addition to the carry-on bag.
- Pets may be carried in addition to the carry-on bag.
- All duty free items purchased after the security check may also be carried onto the aircraft.

Maximum Size for Carry-On Bag

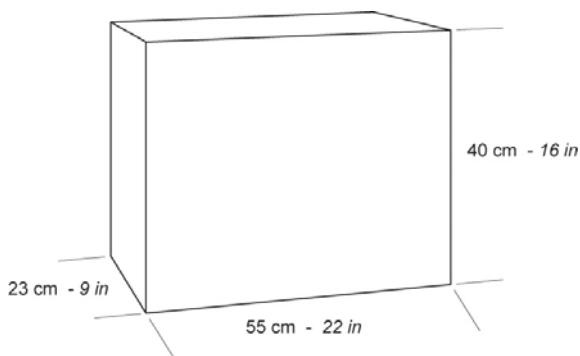

EXCEPTIONS TO CARRY-ON BAG LIMIT

